

M120

CRANE RAIL CLIPS

weldable and interlocking adjustment

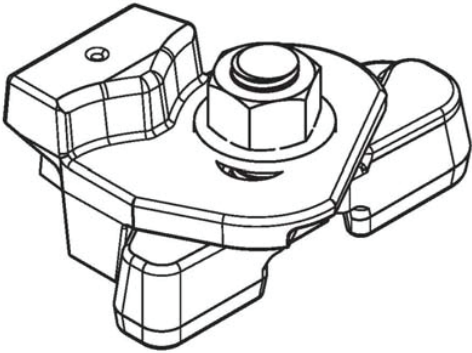

FEATURES

Patented system of the rubber pressure block installation prevents the escape of the pressure block from the rail clip during the life of the installation.

COMPONENTS INCLUDED

- upper rail clip
- rubber pressure block
- weldable base
- M16 class 10.9 heavy hex bolt
- bolt nut

DIMENSIONS

M120 Rail Clip	Height	51mm
	Footprint	51mm
	Length	110mm
	A	06mm

CALCULATIONS

Rail	F: rail width	S: F+(2 x 6mm)	D: F+(2 x 51mm)	R: F+(2 x 69mm)
Example: 41kg	127mm	139mm	229mm	265mm
Your rail:	mm	mm	mm	mm

inform rail

RAIL SOLUTIONS AUSTRALIA

sales@informsteel.com.au | (03) 6184 7188

SPECIFICATIONS

Lateral Resistance.....**120kN**

Adjustment.....**13mm**

INSTALLATION

Tightening Torque..... **200 Nm**

M16 class **10.9** heavy hex head structural bolt.

