

M71

CRANE RAIL CLIPS

weldable and interlocking adjustment

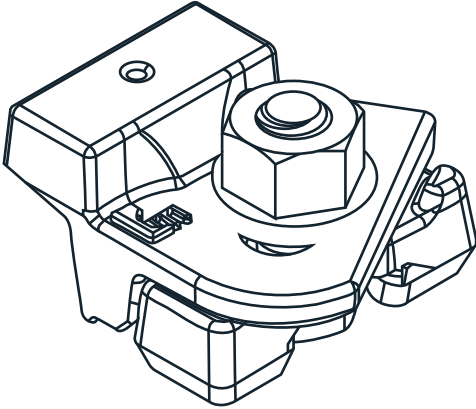

FEATURES

Patented system of the rubber pressure block installation prevents the escape of the pressure block from the rail clip during the life of the installation.

COMPONENTS INCLUDED

- upper rail clip
- rubber pressure block
- weldable base
- A325 heavy hex bolt
- bolt nut

DIMENSIONS

M71 Rail Clip	Height	40mm
	Footprint	45mm
	Length	65mm
	A	06mm

CALCULATIONS

Rail	F: rail width	S: F+(2 x 6mm)	D: F+(2 x 45mm)	R: F+(2 x 59mm)
Example: 41kg	127mm	139mm	217mm	245mm
Your rail: ____	____mm	____mm	____mm	____mm

inform rail

RAIL SOLUTIONS AUSTRALIA

sales@informsteel.com.au | (03) 6184 7188

SPECIFICATIONS

Lateral Resistance..... 71 kN

Adjustment.....10mm

INSTALLATION

Tightening Torque..... 75 Nm

Standard 1/2" dia. **A325** heavy hex head structural bolt

